

TO-SNAP LOCK IN A .156±.003  
 [4±0.08] DIA. HOLE IN A  
 .062 [1.57] PANEL THICKNESS

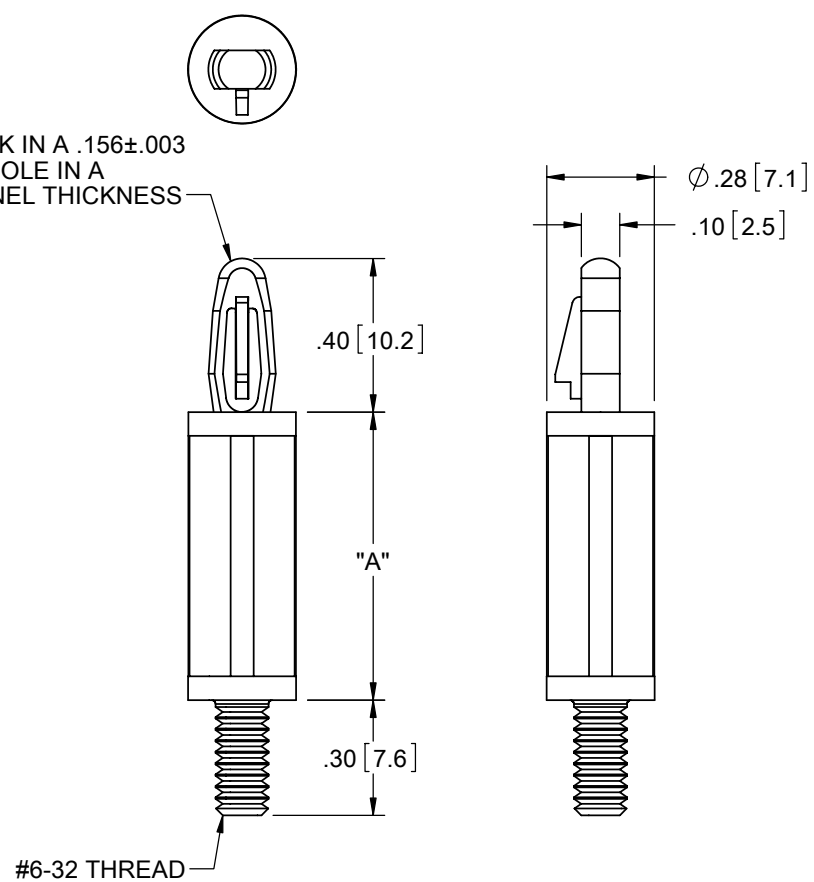

MATERIAL: NYLON 6/6 UL 94 V-2 (RMS-01) COLOR: NATURAL PART NO.	MATERIAL: NYLON 6/6 UL 94 V-2 (RMS-19) COLOR: NATURAL PART NO.	DIM. "A"±.015 [0.4]
LCBS-TM-4-01	LCBS-TM-4-19	1/4 [6.4]
LCBS-TM-6-01	LCBS-TM-6-19	3/8 [9.5]
LCBS-TM-8-01	LCBS-TM-8-19	1/2 [12.7]
LCBS-TM-10-01	LCBS-TM-10-19	5/8 [15.9]
LCBS-TM-12-01	LCBS-TM-12-19	3/4 [19.1]
LCBS-TM-14-01	LCBS-TM-14-19	7/8 [22.2]
LCBS-TM-16-01	LCBS-TM-16-19	1 [25.4]

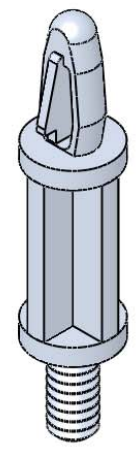

- NOTES:  
 1. M4 THREAD AVAILABLE BY SPECIAL ORDER ONLY.  
 TO ORDER, ADD "-M4" TO PART NO.  
 EXAMPLE: LCBS-TN-M4-X-XX"  
 2. ALTERNATE UNITS FOR REFERENCE ONLY.

E REDRAWN, SEE ECN #1208 FOR CHANGES SK 11/29/06			TITLE: LCBS, THREADED MALE				DWG IN IN [MM] FINAL		PRINT TYPE CA	
- SEE ENGINEERING FOR REV A-D			FILE #: LCBS-TM		DWN: SK		APP: RT		PART #	
REV. DESCRIPTION ENGR. DATE			SHEET: 1 OF 1 SHEET SIZE: A		DT: 11/20/06		CHKD: SJ		SEE TABLE	
			RE: RICHCO, INC.		RICHCO, INC. ENG@RICHCO-INC.COM (773) 539-4060					

CREATED USING  
 SOLIDWORKS  
 TOLERANCES  
 UNLESS NOTED  
 .XX=±.010  
 .XXX=±.005  
 FRAC.=±1/64  
 ANG.=±1°